

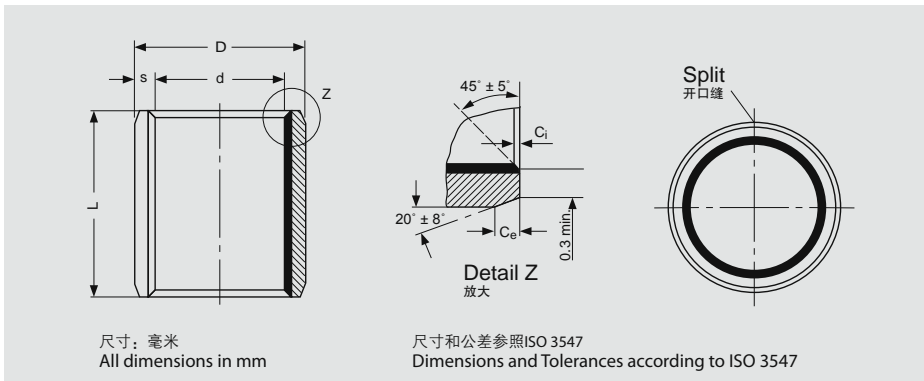

5 规格和公差 Specification & Tolerance

5.1 EU 直套规格及公差 EU Sleeve Bushing Specification & Tolerance



内外倒角尺寸表 Inside & Outside Chamfers

壁厚 Wall thickness S	内倒角 Inside Chamfer C_i	外倒角 Outside Chamfer C_e
0.75	0.25 ± 0.15	0.50 ± 0.30
1.00	0.30 ± 0.20	0.60 ± 0.40
1.50	0.40 ± 0.30	0.60 ± 0.40
2.00	0.40 ± 0.30	1.20 ± 0.40
2.50	0.60 ± 0.40	1.80 ± 0.60

直套型号标注方式 Bushing Symbol

直套型号标注方式 Bushes Symbol	EU - □	× ×	× ×
直套型号 Bushing Type			
直套内径 Bushing I.D.			
直套高度 Bushing Length			

内径 Internal Diameter (I.D.)			外径 External Diameter (O.D.)			高度 Length	壁厚 Wall Thickness	型号 Part No
内径 d	装配轴径 Shaft- Φd_s	装配后内孔尺寸 Φd_i	外径 D	装配座孔 Housing- ΦD_H	理论外径公差 O.D. ΦD_t	ID<80 L ± 0.25 ID>80 L ± 0.50	S	
4	4.000 3.992	4.048 4.000	5.5	5.508 5.500		4	0.750 0.730	EU 0404
						6		EU 0406
						10		EU 0410
5	4.990 4.978	5.055 4.990	7	7.015 7.000		5		EU 0505
						8		EU 0508
						10		EU 0510
6	5.990 5.978	6.055 5.990	8	8.015 8.000	+0.055 +0.025	4	1.005 0.980	EU 0604
						6		EU 0606
						8		EU 0608
						10		EU 0610
7	6.987 6.972	7.055 6.990	9	9.015 9.000		5		EU 0705
						10		EU 0710
8	7.987 7.972	8.055 7.990	10	10.015 10.000		6		EU 0806
						8		EU 0808
						10		EU 0810
						12		EU 0812



内径 Internal Diameter(I.D.)			外径 External Diameter(O.D.)			高度 Length	壁厚 Wall Thickness	型号 Part No
内径 d	装配轴径 Shaft- Φd_s	装配后内孔尺寸 Φd_i	外径 D	装配座孔 Housing- ΦD_H	理论外径公差 O.D. ΦD_t	ID<80 L \pm 0.25 ID>80 L \pm 0.50	S	
10	9.987 9.972	10.058 9.990	12	12.018 12.000		8	1.005 0.980	EU 1008
						10		EU 1010
						12		EU 1012
						15		EU 1015
						20		EU 1020
12	11.984 11.966	12.058 11.990	14	14.018 14.000		8	EU 1208	
						10	EU 1210	
						12	EU 1212	
						15	EU 1215	
						20	EU 1220	
13	12.984 12.966	13.058 12.990	15	15.018 15.000		25	EU 1225	
						10	EU 1310	
						15	EU 1315	
						20	EU 1320	
						5	EU 1405	
14	13.984 13.966	14.058 13.990	16	16.018 16.000	+0.065 +0.030	10	EU 1410	
						12	EU 1412	
						15	EU 1415	
						20	EU 1420	
						25	EU 1425	
15	14.984 14.966	15.058 14.990	17	17.018 17.000		10	EU 1510	
						12	EU 1512	
						15	EU 1515	
						20	EU 1520	
						25	EU 1525	
16	15.984 15.966	16.058 15.990	18	18.018 18.000		10	EU 1610	
						12	EU 1612	
						15	EU 1615	
						20	EU 1620	
						25	EU 1625	
18	17.984 17.966	18.061 17.990	20	20.021 20.000	+0.075 +0.035	10	EU 1810	
						15	EU 1815	
						20	EU 1820	
						25	EU 1825	



内径 Internal Diameter(I.D.)			外径 External Diameter(O.D.)			高度 Length	壁厚 Wall Thickness	型号 Part No
内径 d	装配轴径 Shaft- Φd_s	装配后内孔尺寸 Φd_i	外径 D	装配座孔 Housing- ΦD_H	理论外径公差 O.D. ΦD_t	ID<80 L \pm 0.25 ID>80 L \pm 0.50	S	
20	19.980 19.959	20.071 19.990	23	23.021 23.000		10	1.505 1.475	EU 2010
						15		EU 2015
						20		EU 2020
						25		EU 2025
						30		EU 2030
22	21.980 21.959	22.071 21.990	25	25.021 25.000		15		EU 2215
						20		EU 2220
						25		EU 2225
						30		EU 2230
24	23.980 23.959	24.071 23.990	27	27.021 27.000	+0.075 +0.035	15		EU 2415
						20		EU 2420
						25		EU 2425
						30		EU 2430
25	24.980 24.959	25.071 24.990	28	28.021 28.000		15		EU 2515
						20		EU 2520
						25		EU 2525
						30		EU 2530
						40		EU 2540
28	27.980 27.959	28.085 27.990	32	32.025 32.000		15		EU 2815
						20		EU 2820
						25	EU 2825	
						30	EU 2830	
						10	EU 3010	
30	29.980 29.959	30.085 29.990	34	34.025 34.000	+0.085 +0.045	15	EU 3015	
						20	EU 3020	
						25	EU 3025	
						30	EU 3030	
						40	EU 3040	
32	31.975 31.950	32.085 31.990	36	36.025 36.000		20	EU 3220	
						25	EU 3225	
						30	EU 3230	
						35	EU 3235	
						40	EU 3240	



内径 Internal Diameter(I.D.)			外径 External Diameter(O.D.)			高度 Length	壁厚 Wall Thickness	型号 Part No
内径 d	装配轴径 Shaft- Φd_s	装配后内孔尺寸 Φd_i	外径 D	装配座孔 Housing- ΦD_H	理论外径公差 O.D. ΦD_t	ID<80 L \pm 0.25 ID>80 L \pm 0.50	S	
35	34.975 34.950	35.085 34.990	39	39.025 39.000		20	2.005 1.970	EU 3520
						30		EU 3530
						35		EU 3535
						40		EU 3540
						50		EU 3550
40	39.975 39.950	40.085 39.990	44	44.025 44.000	+0.085 +0.045	12		EU 4012
						20		EU 4020
						25		EU 4025
						30		EU 4030
						40		EU 4040
45	44.975 44.950	45.105 44.990	50	50.025 50.000		50	EU 4050	
						20	EU 4520	
						30	EU 4530	
						40	EU 4540	
						45	EU 4545	
50	49.975 49.950	50.110 49.990	55	55.030 55.000		50	EU 4550	
						20	EU 5020	
						30	EU 5030	
						40	EU 5040	
						50	EU 5050	
55	54.970 54.940	55.110 54.990	60	60.030 60.000	+0.100 +0.055	60	EU 5060	
						20	EU 5520	
						25	EU 5525	
						30	EU 5530	
						40	EU 5540	
60	59.970 59.940	60.110 59.990	65	65.030 65.000		55	EU 5555	
						60	EU 5560	
						20	EU 6020	
						30	EU 6030	
						40	EU 6040	
60	59.970 59.940	60.110 59.990	65	65.030 65.000		50	EU 6050	
						60	EU 6060	
						70	EU 6070	



内径 Internal Diameter(I.D.)			外径 External Diameter(O.D.)			高度 Length	壁厚 Wall Thickness	型号 Part No		
内径 d	装配轴径 Shaft- Φd_s	装配后内孔尺寸 Φd_i	外径 D	装配座孔 Housing- ΦD_H	理论外径公差 O.D. ΦD_t	ID<80 L \pm 0.25 ID>80 L \pm 0.50	S			
65	64.970 64.940	65.110 64.990	70	70.030 70.000		30	2.505 2.460	EU 6530		
						50		EU 6550		
						70		EU 6570		
70	69.970 69.940	70.110 69.990	75	75.030 75.000	+0.100 +0.055	40		2.505 2.460	EU 7040	
						50			EU 7050	
						70			EU 7070	
75	74.970 74.940	75.110 74.990	80	80.030 80.000		60			2.490 2.440	EU 7560
						80				EU 7580
						60				EU 8060
80	80.000 79.946	80.155 80.020	85	85.035 85.000		80	2.490 2.440			EU 8080
						100				EU 80100
						60				EU 8560
85	85.000 84.946	85.155 85.020	90	90.035 90.000		80		2.490 2.440		EU 8580
						100				EU 85100
						60				EU 9060
90	90.000 89.946	90.155 90.020	95	95.035 95.000		80			2.490 2.440	EU 9080
						100				EU 90100
						60				EU 9560
95	95.000 94.946	95.155 95.020	100	100.035 100.000		80	2.490 2.440			EU 9580
						100				EU 95100
						50				EU 10050
100	100.000 99.946	100.155 100.020	105	105.035 105.000	+0.120 +0.070	60		2.490 2.440		EU 10060
						80				EU 10080
						100				EU 100100
105	105.000 104.946	105.155 105.020	110	110.035 110.000		60			2.490 2.440	EU 10560
						80				EU 10580
						100				EU 105100
110	110.000 109.946	110.155 110.020	115	115.035 115.000		60	2.490 2.440			EU 11060
						80				EU 11080
						100				EU 110100
115	115.000 114.946	115.155 115.020	120	120.035 120.000		60		2.465 2.415		EU 11560
						70				EU 11570
						50				EU 12050
120	120.000 119.946	120.210 120.070	125	125.040 125.000		60			2.465 2.415	EU 12060
						100				EU 120100
						60				EU 12560
125	125.000 124.937	125.210 125.070	130	130.040 130.000	+0.170 +0.100	80	2.465 2.415			EU 12580
						100				EU 125100
						60				EU 13060
130	130.000 129.937	130.210 130.070	135	135.040 135.000		80		2.465 2.415		EU 13080
						100				EU 130100
						60				



内径 Internal Diameter(I.D.)			外径 External Diameter(O.D.)			高度 Length	壁厚 Wall Thickness	型号 Part No
内径 d	装配轴径 Shaft- Φd_s	装配后内孔尺寸 Φd_i	外径 D	装配座孔 Housing- ΦD_H	理论外径公差 O.D. ΦD_t	ID<80 L \pm 0.25 ID>80 L \pm 0.50	S	
135	135.000 134.937	135.210 135.070	140	140.040 140.000		60	2.465 2.415	EU 13560
						80		EU 13580
						100		EU 135100
140	140.000 139.937	140.210 140.070	145	145.040 145.000	+0.170 +0.100	60		EU 14060
						80		EU 14080
						100		EU 140100
150	150.000 149.937	150.210 150.070	155	155.040 155.000		60		EU 15060
						80		EU 15080
						100		EU 150100
160	160.000 159.937	160.210 160.070	165	165.040 165.000		80		EU 16080
						100		EU 160100
180	180.000 179.937	180.216 180.070	185	185.046 185.000		80		EU 18080
						100		EU 180100
200	200.000 199.928	200.216 200.070	205	205.046 205.000	+0.210 +0.130	80		EU 20080
						100		EU 200100
210	210.000 209.928	210.216 210.070	215	215.046 215.000		80		EU 21080
						100		EU 210100
220	220.000 219.928	220.216 220.070	225	225.046 225.000		80		EU 22080
						100	EU 220100	
250	250.000 249.928	250.222 250.070	255	255.052 255.000		80	EU 25080	
						100	EU 250100	
280	280.000 279.948	280.222 280.070	285	285.052 285.000	+0.260 +0.170	80	EU 28080	
						100	EU 280100	
300	300.000 299.919	300.222 300.070	305	305.052 305.000		80	EU 30080	
						100	EU 300100	



5.2 EU 翻边轴套规格及公差 EU Flange Bushing Specification & Tolerance

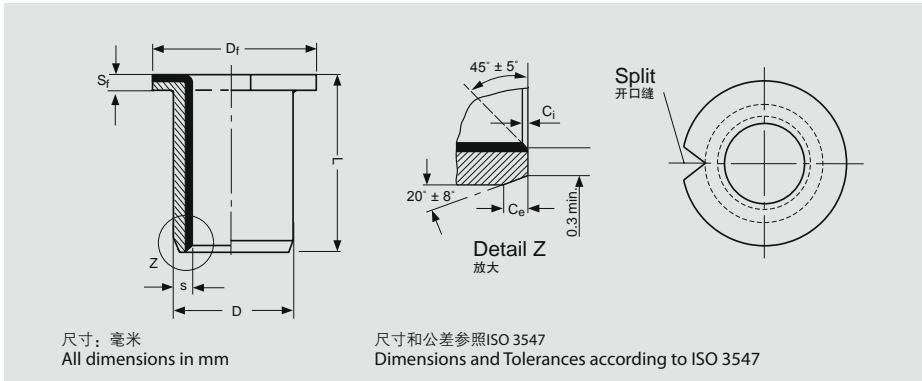

内外倒角尺寸表 Inside & Outside Chamfers

壁厚 Wall thickness S	内倒角 Inside Chamfer C _i	外倒角 Outside Chamfer C _o
0.75	0.25 ± 0.15	0.50 ± 0.30
1.00	0.30 ± 0.20	0.60 ± 0.40
1.50	0.40 ± 0.30	0.60 ± 0.40
2.00	0.40 ± 0.30	1.20 ± 0.40
2.50	0.60 ± 0.40	1.80 ± 0.60

翻边套型号标注方式 Flange Bushing Symbol

翻边套型号标注方式 Flange Bushing Symbol	EU-□	F	× ×	× ×
轴承型号 Flange Bushing Type				
翻边套 Flange				
翻边套内径 Flange Bushing Inner Diameter				
翻边套高度 Flange Bushing Length				

内径 Internal Diameter			外径 External Diameter			法兰厚度 Flang Wall S _f	法兰外径 Flang Φ D _f	高度 Length	壁厚 Wall Thickness	型号 Part No	
内径 d	装配轴径 Shaft Φ d _s	装配后内孔尺寸 Φ d _i	外径 D	装配座孔 Housing Φ D _H	理论外径公差 O.D. Φ D _t	max. min.	max. min.	L ± 0.25	S		
6	5.990	6.055	8	8.015	+0.055 +0.025	1.050 0.800	12.50	4	1.005 0.980	EU F06040	
	5.978	5.990		8.000			11.50	8		EU F06080	
8	7.987	8.005	10	10.015			15.50	5.5		EU F08055	
	7.972	7.990		10.000			14.50	7.5		EU F08075	
							9.5	EU F08095			
10	9.987	10.058	12	12.018			18.50	7		EU F10070	
	9.972	9.990		12.000			17.50	9		EU F10090	
							12	EU F10120			
							17	EU F10170			
12	11.984	12.058	14	14.018			+0.065 +0.030	20.50 19.50		7	EU F12070
	11.966	11.990		14.000						9	EU F12090
										12	EU F12120
					17	EU F12170					



内径 Internal Diameter			外径 External Diameter			法兰厚度 Flang Wall S_f	法兰外径 Flang Φ D_f	高度 Length	壁厚 Wall Thickness	型号 Part No				
内径 d	装配轴径 Shaft Φd_s	装配后内孔尺寸 Φd_i	外径 D	装配座孔 Housing ΦD_H	理论外径公差 O.D. ΦD_t	max. min.	max. min.	$L \pm 0.25$	S					
14	13.984 13.966	14.058 13.990	16	16.018 16.000	+0.065 +0.030	1.050 0.800	22.50 21.50	12	1.005 0.980	EU F14120				
								17		EU F14170				
15	14.984 14.966	15.058 14.990	17	17.018 17.000				23.50 22.50		9	EU F15090			
										12	EU F15120			
										17	EU F15170			
16	15.984 15.966	16.058 15.990	18	18.018 18.000				24.50 23.50		12	EU F16120			
										17	EU F16170			
18	17.984 17.966	18.061 17.990	20	20.021 20.000				26.50 25.50		12	EU F18120			
										17	EU F18170			
										22	EU F18220			
20	19.980 19.959	20.071 19.990	23	23.021 23.000	+0.075 +0.035	1.600 1.300	30.50 29.50	11.5	1.505 1.475	EU F20115				
								16.5		EU F20165				
								21.5		EU F20215				
25	24.980 24.959	25.071 24.990	28	28.021 28.000				35.50 34.50		11.5	EU F25115			
										16.5	EU F25165			
										21.5	EU F25215			
30	29.980 29.959	30.085 29.990	34	34.025 34.000				2.100 1.800		42.50 41.50	16	2.005 1.970	EU F30160	
											26		EU F30260	
35	34.975 34.950	35.085 34.990	39	39.025 39.000							47.50 46.50		16	EU F35160
													26	EU F35260
40	39.975 39.950	40.085 39.990	44	44.025 44.000	+0.085 +0.045	53.50 52.50	16		EU F40160					
							26		EU F40260					
45	44.975 44.950	45.105 44.990	50	50.025 50.000		2.600 2.300	58.50 57.50		16		EU F45160			
									26		EU F45260			



5.3 EU 垫片规格及公差 EU Thrust washer Specification & Tolerance

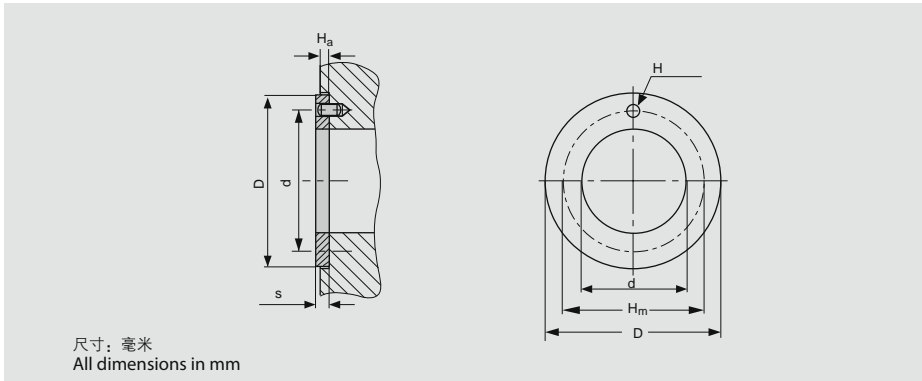

垫片型号标注方式

Washer Symbol

垫片型号标注方式 Washer Symbol	WC	× ×	EU - □
垫片 Washer			
垫片内径 Washer I.D.			
垫片型号 Washer Type			

内孔 Internal Diameter Φ d		外径 External Diameter Φ D		壁厚 Thickness s	定位孔大小 Dowel Hole Φ H	定位孔中心距 Dowel Hole PCD Φ Hm	装配深度 Recess Depth H _a	型号 Part No
min	max	min.	max.	max. min.	max. min.	Φ ±0.125	max. min.	
10.00	10.25	19.75	20.00	1.50 1.40	无孔 No Hole	无孔 No Hole	1.20 0.80	WC 10 EU
12.00	12.25	23.75	24.00		1.90 1.60	18		WC 12 EU
14.00	14.25	25.75	26.00		2.40 2.10	20		WC 14 EU
16.00	16.25	29.75	30.00			22		WC 16 EU
18.00	18.25	31.75	32.00		3.40 3.10	25		WC 18 EU
20.00	20.25	35.75	36.00			28		WC 20 EU
22.00	22.25	37.75	38.00		4.40 4.10	30		WC 22 EU
24.00	24.25	41.75	42.00			33		WC 24 EU
26.00	26.25	43.75	44.00		2.00 1.95	35		WC 26 EU
28.00	28.25	47.75	48.00			38		WC 28 EU
32.00	32.25	53.75	54.00		1.70 1.30	43		WC 32 EU
38.00	38.25	61.75	62.00			50		WC 38 EU
42.00	42.25	65.75	66.00		61	54		WC 42 EU
48.00	48.25	73.75	74.00			65		WC 48 EU
52.00	52.25	77.75	78.00	76	76	WC 52 EU		
62.00	62.25	89.75	90.00				WC 62 EU	



5.4 EU 板材规格及公差 EU Strip Specification

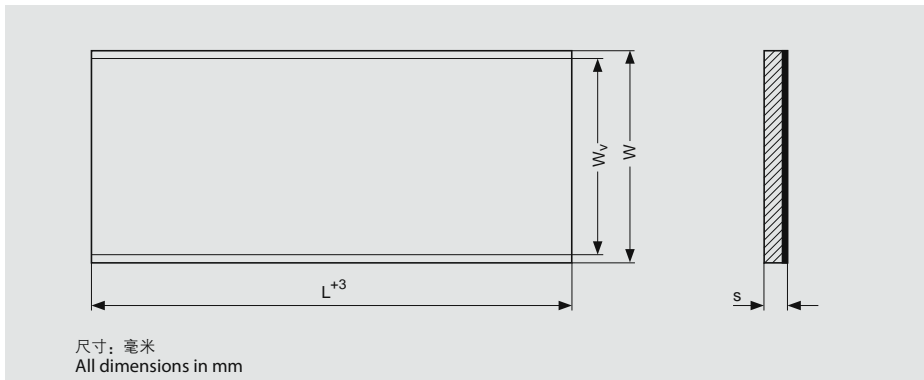

板材标注方式 Strip Symbol

板材标注方式 Strip Symbol	S	× ×	× ×	EU - □
板材 Strip				
板材厚度 Strip Wall Thickness				
板材宽度 Strip Width				
板材型号 Strip Type				

长度 Length L	宽度 Total Width W	有效宽度 Useable Width W_u	厚度 Thickness S-0.05	型号 Part No
500	160	150	0.75	S 07150 EU
500	225	215	1.00	S 10215 EU
500	254	245	1.50	S 15245 EU
500	254	245	2.00	S 20245 EU
500	254	245	2.50	S 25245 EU
500	254	245	3.00	S 30245 EU



5.4 EU 英制直套规格及公差
EU Inch Sleeve Bushing Specification & Tolerance

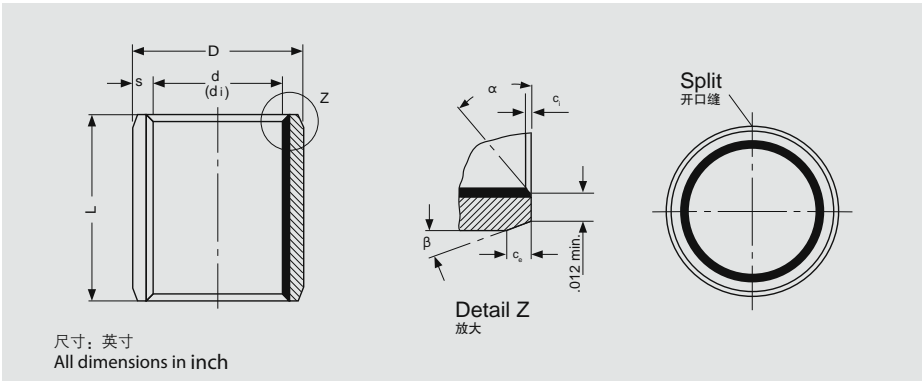

内外倒角尺寸表
Inside & Outside Chamfers

壁厚 Wall thickness	内倒角 ID Chamfer		外倒角 OD Chamfer	
	C_i	α	C_o	β
0.0315"	0.008"- 0.024"	30°- 45°	0.004"- 0.012"	30°- 45°
0.0471"	0.020"- 0.040"	20°- 30°	0.005"- 0.025"	40°- 55°
0.0627"-0.0928"	0.020"- 0.040"	15°- 25°	0.005"- 0.025"	40°- 50°

直套型号标注方式
Bushings Symbol

直套型号标注方式 Bushes Symbol	× ×	EU - □	× ×
直套内径 Bushing I. D.			
直套型号 Bushing Type			
直套高度 Bushing Length			

内径 Internal Diameter			外径 External Diameter		高度 Length	壁厚 Wall Thickness	型号 Part No	
内径 d	装配轴径 Shaft- Φd_s	装配后内孔尺寸 Φd_i	外径 D	装配座孔 Housing- ΦD_H	$L \pm 0.01"$	S		
3/16	0.1865 0.1858	0.1893 0.1867	1/4	0.2503 0.2497	0.1875	0.0315 0.0305	03EU03	
					0.2500		03EU04	
					0.3700		03EU06	
1/4	0.2490 0.2481	0.2518 0.2492	5/16	0.3128 0.3122	0.2500		04EU04	
					0.3750		04EU06	
5/16	0.3115 0.3106	0.3143 0.3117	3/8	0.3753 0.3747	0.5000		05EU06	
					0.3750		05EU08	
3/8	0.3740 0.3731	0.3769 0.3742	15/32	0.4691 0.4684	0.3750		0.0471 0.0461	06EU06
					0.5000			06EU08
					0.7500			06EU12
7/16	0.4365 0.4355	0.4394 0.4367	17/32	0.5316 0.5309	0.5000			07EU08
					0.7500			07EU12
1/2	0.4990 0.4980	0.5019 0.4992	19/32	0.5941 0.5934	0.3750	0.0471 0.0461		08EU06
					0.5000			08EU08
					0.6250			08EU10
					0.8750			08EU14



内径 Internal Diameter			外径 External Diameter		高度 Length	壁厚 Wall Thickness	型号 Part No
内径 d	装配轴径 Shaft-Φ d _s	装配后内孔尺寸 Φ d _i	外径 D	装配座孔 Housing-Φ D _H	L ± 0.01"	S	
9/16	0.5615 0.5605	0.5644 0.5617	21/32	0.6566 0.6559	0.5000	0.0471 0.0461	09EU08
					0.7500		09EU12
5/8	0.6240 0.6230	0.6270 0.6242	23/32	0.7192 0.7184	0.5000		10 EU 08
					0.6250		10 EU 10
					0.7500		10 EU 12
					0.8750		10 EU 14
3/4	0.7491 0.7479	0.7525 0.7493	7/8	0.8755 0.8747	0.5000		12 EU 08
					0.7500		12 EU 12
					1.0000		12 EU 16
7/8	0.8741 0.8729	0.8775 0.8743	1	1.0005 0.9997	0.7500		14 EU 12
					0.8750		14 EU 14
					1.000		14 EU 16
1	0.9991 0.9979	1.0026 0.9992	1 1/8	1.1256 1.1246	0.7500		16 EU 12
					1.0000		16 EU 16
					1.5000		16 EU 24
1 1/8	1.1238 1.1226	1.1278 1.1240	1 9/32	1.2818 1.2808	0.7500		18 EU 12
					1.0000	18 EU 16	
1 1/4	1.2488 1.2472	1.2528 1.2490	1 13/32	1.4068 1.4058	0.7500	20 EU 12	
					1.0000	20 EU 16	
					1.2500	20 EU 20	
					1.7500	20 EU 28	
1 3/8	1.3738 1.3722	1.3778 1.3740	1 17/32	1.5318 1.5308	1.0000	22 EU 16	
					1.3750	22 EU 22	
					1.7500	22 EU 28	
1 1/2	1.4988 1.4972	1.5028 1.4990	1 21/32	1.6568 1.6558	1.0000	24 EU 16	
					1.2500	24 EU 20	
					1.5000	24 EU 24	
					2.0000	24 EU 32	
1 5/8	1.6238 1.6222	1.6278 1.6240	1 25/32	1.7818 1.7808	1.0000	26 EU 16	
					1.5000	26 EU 24	
1 3/4	1.7487 1.7471	1.7535 1.7489	1 15/16	1.9381 1.9371	1.0000	28 EU 16	
					1.5000	28 EU 24	
					1.7500	28 EU 28	
					2.0000	28 EU 32	



内径 Internal Diameter			外径 External Diameter		高度 Length	壁厚 Wall Thickness	型号 Part No
内径 d	装配轴径 Shaft- Φd_s	装配后内孔尺寸 Φd_i	外径 D	装配座孔 Housing- ΦD_H	$L \pm 0.01''$	S	
1 ⁷ / ₈	1.8737 1.8721	1.8787 1.8739	2 ¹ / ₁₆	2.0633 2.0621	1.0000	0.0941 0.0923	30EU16
					1.8750		30EU30
					2.2500		30EU36
2	1.9987 1.9969	2.0037 1.9989	2 ³ / ₁₆	2.1883 2.1871	1.0000		32EU16
					1.5000		32EU24
					2.0000		32EU32
					2.5000		32EU40
2 ¹ / ₄	2.2507 2.2489	2.2573 2.2509	2 ⁷ / ₁₆	2.4377 2.4365	2.0000		36EU32
					2.2500		36EU36
					2.5000		36EU40
					3.0000		36EU48
2 ¹ / ₂	2.5011 2.4993	2.5077 2.5013	2 ¹¹ / ₁₆	2.6881 2.6869	2.0000		40EU32
					2.5000	40EU40	
					3.0000	40EU48	
					3.5000	40EU56	
2 ³ / ₄	2.7500 2.7482	2.7566 2.7502	2 ¹⁵ / ₁₆	2.9370 2.9358	2.0000	44EU32	
					2.5000	44EU40	
					3.0000	44EU48	
					3.5000	44EU56	
3	3.0000 2.9982	3.0068 3.0002	3 ³ / ₁₆	3.1872 3.1858	2.5000	48EU32	
					3.0000	48EU48	
					3.7500	48EU60	
3 ¹ / ₂	3.5000 3.4978	3.5068 3.5002	3 ¹¹ / ₁₆	3.6872 3.6858	2.5000	56EU40	
					3.0000	56EU48	
					3.7500	56EU60	
4	4.0000 3.9978	4.0068 4.0002	4 ³ / ₁₆	4.1872 4.1858	3.0000	64EU48	
					3.7500	64EU60	
					4.7500	64EU76	
5	4.9986 4.9961	5.0056 4.9988	5 ³ / ₁₆	5.1860 5.1844	3.0000	80EU48	
					3.7500	80EU60	
6	6.0000 5.9975	6.0070 6.0002	6 ³ / ₁₆	6.1874 6.1858	3.0000	96EU48	
					3.7500	96EU60	
7	6.9954 6.9929	7.0026 6.9956	7 ³ / ₁₆	7.1830 7.1812	3.7500	112EU60	



5.6 EU 英制翻边规格及公差 EU Inch Flange Bushing Specification & Tolerance

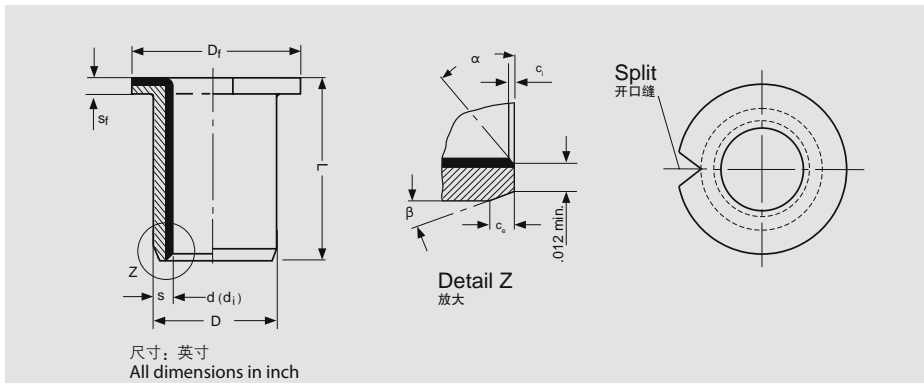

内外倒角尺寸表
Inside & Outside Chamfers

壁厚 Wall thickness	内倒角 ID Chamfer		外倒角 OD Chamfer	
	C _i	α	C _e	β
0.0315"	0.008"-0.024"	30°-45°	0.004"-0.012"	30°-45°
0.0471"	0.020"-0.040"	20°-30°	0.005"-0.025"	40°-55°
0.0627"-0.0928"	0.020"-0.040"	15°-25°	0.005"-0.025"	40°-50°

翻边套型号标注方式
Flange Bushing Symbol

翻边套型号标注方式 Flange Bushing Symbol	× ×	F	EU - □	× ×
翻边套内径 Flange Bushing I. D.				
翻边套 Flange				
轴承型号 Flange Bushing Type				
翻边套高度 Flange Bushing Length				

内径 d	装配轴径 Shaft-Φ d _s	装配后内孔尺寸 Φ d _i	装配座孔 Housing Φ D _H	法兰厚度 Flang Wall S _f	法兰外径 Flang Φ D _F	高度 Length	型号 Part No
						L ± 0.01"	
3/8	0.3750 0.3740	0.4684 0.4691	0.3752 0.3779	0.052 0.044	11/16	1/4	06F EU04
						3/8	06F EU06
						1/2	06F EU08
1/2	0.5000 0.4990	0.5934 0.5941	0.5002 0.5029	0.052 0.044	13/16	1/4	08F EU04
						3/8	08F EU06
						1/2	08F EU08
5/8	0.6250 0.6240	0.7184 0.7192	0.6252 0.6280	0.052 0.044	15/16	3/8	10F EU06
						1/2	10F EU08
						5/8	10F EU10
3/4	0.7500 0.7488	0.8747 0.8755	0.7502 0.7534	0.068 0.060	1 1/8	3/8	12F EU06
						1/2	12F EU08
						3/4	12F EU12
7/8	0.8750 0.8738	0.9997 1.0005	0.8752 0.8784	0.068 0.060	1 3/8	1/2	14F EU08
						3/4	14F EU12
						1	14F EU16
1	1.0000 0.9988	1.1247 1.1255	1.0002 1.0034	0.068 0.060	1 3/4	1/2	16F EU08
						3/4	16F EU12
						1	16F EU16



5.7 EU 英制垫片规格及公差 EU Inch Thrust Washer Specification & Tolerance

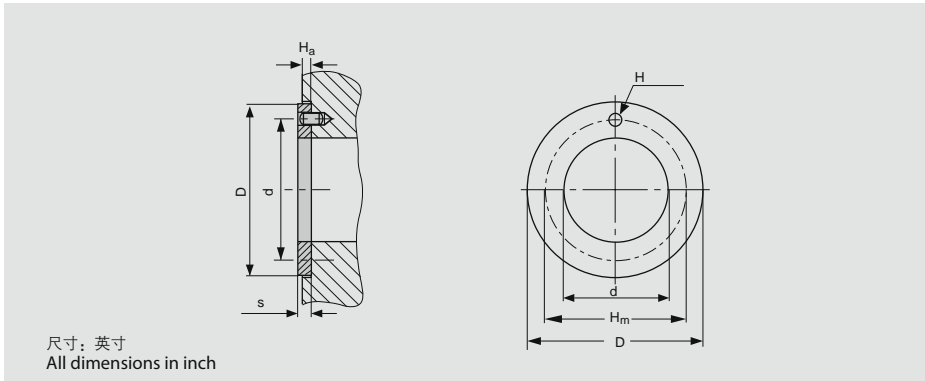

垫片型号标注方式

Washer Symbol

垫片型号标注方式 Washer Symbol	EU - □	WC	× ×
垫片型号 Washer Type			
垫片 Washer			
垫片内径 Washer I.D.			

内径 Internal Diameter d		外径 External Diameter D		壁厚 Thickness s	定位孔中心 Dowel Hole PCD-Φ $H_m \pm 0.12$	定位孔直径 Dowel Hole-Φ H	Recess Depth H_a	型号 Part No
min.	max.	min.	max.	max. min.	max. min.	$\pm 0.005''$	max. min.	
0.510	0.500	0.865	0.875	0.063 0.061	0.077 0.067	0.6870	0.050 0.040	EU 06
0.572	0.562	0.990	1.000			0.7810		EU 07
0.635	0.625	1.115	1.125		0.109 0.099	0.8750		EU 08
0.697	0.687	1.177	1.187			0.9370		EU 09
0.760	0.750	1.240	1.250			1.0000		EU 10
0.822	0.812	1.365	1.375			1.0940		EU 11
0.885	0.875	1.490	1.500			1.1870		EU 12
1.010	1.000	1.740	1.750			1.3750		EU 14
1.135	1.125	1.990	2.000		0.171 0.161	1.5620		EU 16
1.260	1.250	2.115	2.125			1.6870		EU 18
1.385	1.375	2.240	2.250			1.8020		EU 20
1.510	1.500	2.490	2.500			2.0000		EU 22
1.635	1.625	2.615	2.625			2.1250		EU 24
1.760	1.750	2.740	2.750			2.2500		EU 26
2.010	2.000	2.990	3.000	0.202 0.192	2.5000	0.080 0.070	EU 28	
2.135	2.125	3.115	3.125		2.6250		EU 30	
2.260	2.250	3.240	3.250		2.7500		EU 32	